



The N-0125X Short Course

Introduction

This document provides a short synopsis of the various models of the Powerstax N-0125X power supplies, their output voltage and current specifications and their connections. The supplies are high-efficiency line-switching AC to DC power supplies with universal AC input power (100-240VAC 50-60Hz). They're all rated for 125 total DC watts output with full-load efficiencies of up to 90% (model dependent). All models have Power-Factor-Correcting (PFC) AC inputs to reduce input current and harmonic distortion on the AC line.

All models of the N-0125X Series can be used as standalone power supplies while models N-01251 can be used in redundant or N+1 configurations with up to 4 units connected in parallel.

The N-0125X is a UL recognized component and also meets the requirements of CSA, TUV and the CE mark. For complete product details, please refer to the N-0125X product specification at www.powerstaxplc.com.

Safety Warning

The N-0125X is a component, not a stand-alone power supply. It must be mounted inside a protective enclosure to prevent accidental shock by contact with the supply. Lethal voltages are present while and after AC power is applied to the N-0125X. Allow 1-minute for storage capacitors to discharge after removing AC power before handling the N-0125X.

The safety ground connection, at the mounting hole next to the AC input connector, must be connected to the safety ground of the AC power source. The output DC return signals may also be connected to this ground.

Cooling

The N-0125X is rated to supply a total of 125-watts of DC output power at up to 50°C ambient temperature when provided with a forced airflow of at least 5-CFM. The dash 1, 7 and 8 models cannot supply the maximum current from each output simultaneously because the aggregate power is limited to 125-watts. If forced airflow is not provided, the total output power should be reduced to 70-watts at an ambient temperature of 50°C.

We recommend connecting a 12-volt fan (rated at 5-CFM or more) to the auxiliary 12-volt output on every N-0125X model. The fan should be in close proximity to the supply with its airflow axis parallel to the plane of the N-01254 's printed circuit board and the airflow directed to the center of any side of the supply.

Mounting

The N-0125X must be mounted at all four corners as shown in Figure 1.

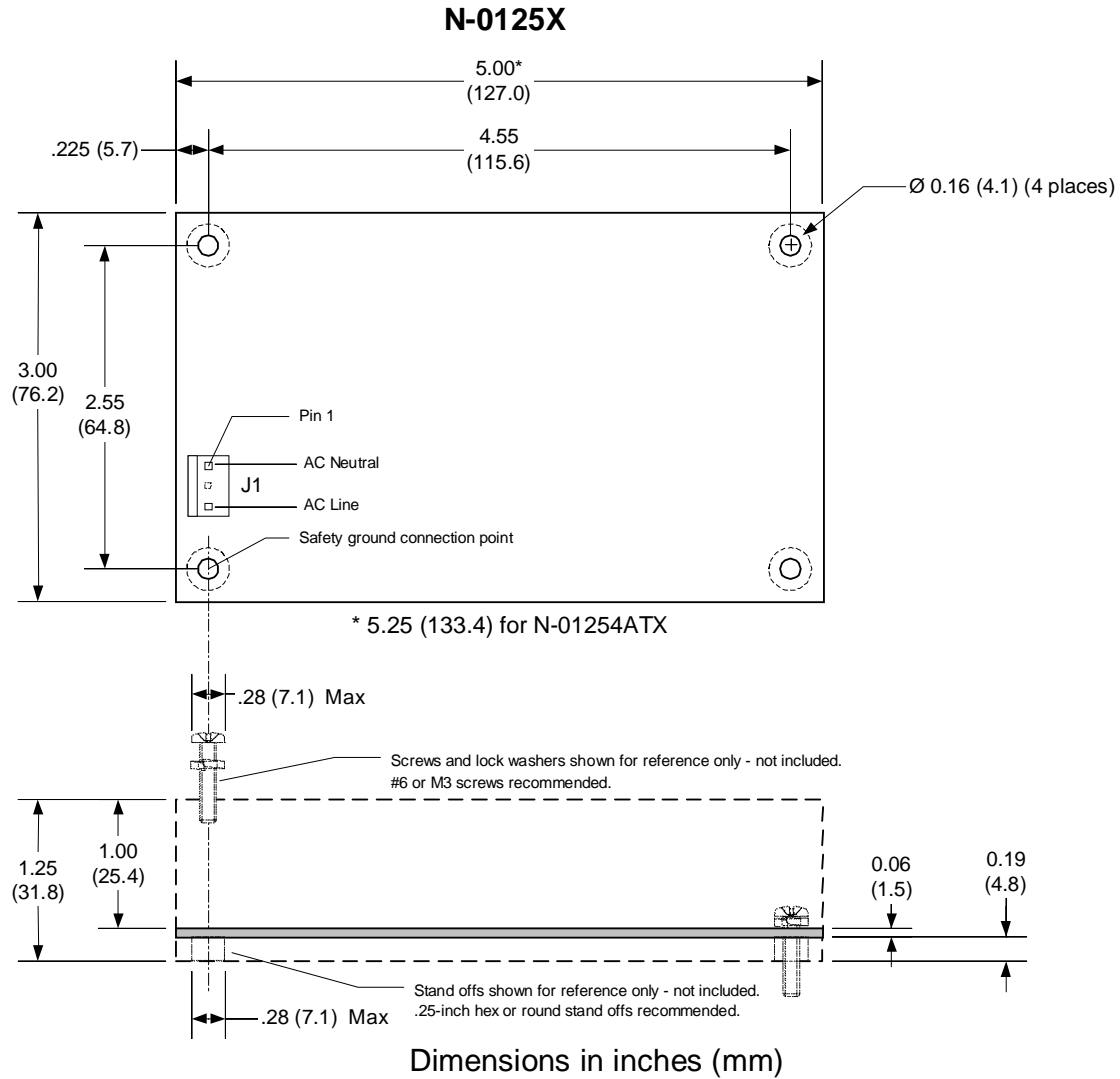

Figure 1 N-0125X Dimensions and Mounting Requirements

The N-0125X Short Course

The Product Label

The black label on the metal cover of the N-0125X contains the model number, “N-0125X-x” where x is the dash number of 1 to 4 that determines the available output voltage(s). While the output voltages are specified on the label, you may also wish to refer to Table 1 below.



Model	Output	Nominal Voltage (VDC)	Maximum Output Current	Remote Sense Available
N-01254-PFC-033	V1	+3.3	12.0 A	V1/RTN
	V2	+5	15.0 A	
	V3	+12	5.0 A	
	V4	-12	0.5 A	
	ATX only	V5 STBY	5	
N-01251-PFC-050	V1	+5	25.0 A	V1/RTN
	V2	+12V _{aux}	0.5 A	
N-01251-PFC-120	V1	+12	10.4 A	V1/RTN
	V2*	12V _{aux}	0.5 A	
N-01251-PFC-150	V1	+15	8.3 A	V1/RTN
	V2*	12V _{aux}	0.5 A	
N-01251-PFC-240	V1	+24	5.2 A	V1/RTN
	V2*	12V _{aux}	0.5 A	
N-01251-PFC-480	V1	+48	2.6 A	V1/RTN
	V2*	12V _{aux}	0.5 A	
N-01254-PFC-025	V1	+2.5	10.0 A	V1/RTN
	V2	+5	15.0 A	
	V3	+12	5.0 A	
	V4	-12	0.5 A	
N-01253	V1	none		RTN only
	V2	+5	15.0 A	
	V3	+12	5.0 A	
	V4	-12	0.5 A	
N-01251-PFC-033	V1	+3.3	32.0 A	V1/RTN
	V2	+12V _{aux}	0.5 A	

Table 1 N-0125X Specification Synopsis (* indicates floating supply for + or – output)



AC Input Connections

AC power is supplied to J1 pins 1 (neutral, white) and 3 (line, black) as shown in Figure 1. A safety ground must be connected to the mounting hole next to J1. This may be a wire equal in size or larger than the AC input lines or a grounded metal chassis connection. The recommended mating housing is a Molex 09-50-8031 using 08-52-0113 (or 08-52-0112) crimp terminals. The terminals are rated for AWG-18 or AWG-20 wire. We recommend UL-1430 style wire or equivalent. Molex recommends using their 11-01-0210 or 11-01-0212 hand crimp tools.

DC Output Connections

The Molex terminals for J2 are rated for 7-amps each with AWG-18 wire and 6.25-amps each with AWG-20 wire. We recommend using UL-1430 style wire. Make certain your application does not exceed the current rating of any single terminal.

J2	N-01254's + N-01253	N-01251 (5V + 3V3)	N-01251 (12V – 48V)
Connector Circuits (pins)	14	10	6
PCB Header	26-60-4140	26-60-4100	26-60-4060
Molex Mating Housing	09-50-8141	09-50-8101	09-50-8061
Machine Crimped Terminal	08-52-0112		
Hand Crimped Terminal	08-52-0113		
Molex Hand Crimp Tool	11-01-0210 or 11-01-0212		

Table 2 J2 Mating Connectors (includes –1ATX)

J3	N-01254's + N-01253	N-01254ATX + 3V3 + 5V	N-01251 (12V – 48V)
Connector Circuits (pins)	3	5	6
Header	22-23-2031	22-23-2051	22-23-2061
Molex Mating Housing	22-01-3037	22-01-3057	22-01-3067
Machine Crimped Terminal	08-50-0113		
Hand Crimped Terminal	08-50-0114		
Molex Hand Crimp Tool	11-01-0185		
Recommended Wire Gauge	AWG 22 thru 30		

Table 3 J3 Mating Connectors

J4	N-01251
Connector Circuits (pins)	2
Header	22-23-2021
Molex Mating Housing	22-01-3027
Machine Crimped Terminal	08-50-0113
Hand Crimped Terminal	08-50-0114
Molex Hand Crimp Tool	11-01-0185
Recommended Wire Gauge	AWG 22 thru 30

Table 4 12V Aux Mating Connector



The N-0125X Short Course

Pin	N-01253 and 4
J2-1	-12V AUX (Fan)
J2-2	+12V
J2-3	V1 (+ Output)
J2-4	V1 (+ Output)
J2-5	V1 (+ Output)
J2-6	DC RETURN (0V)
J2-7	DC RETURN (0V)
J2-8	DC RETURN (0V)
J2-9	DC RETURN (0V)
J2-10	DC RETURN (0V)
J2-11	+5V
J2-12	+5V
J2-13	+5V
J2-14	+5V
J3-1	0V Sense (-)
J3-2	V1 Sense (+)
J3-3	Power Good

Table 5 N-01253 and 4 Pinout

Pin	N-01254ATX
J2-1	-12V AUX (Fan)
J2-2	+12V
J2-3	V1 (+ Output)
J2-4	V1 (+ Output)
J2-5	V1 (+ Output)
J2-6	DC RETURN (0V)
J2-7	DC RETURN (0V)
J2-8	DC RETURN (0V)
J2-9	DC RETURN (0V)
J2-10	DC RETURN (0V)
J2-11	+5V
J2-12	+5V
J2-13	+5V
J2-14	+5V
J3-1	0V Sense (-)
J3-2	V1 Sense (+)
J3-3	Power Good
J3-4	Remote On/Off
J3-5	+5V Standby

Table 6 N-01254 -1ATX Pinout

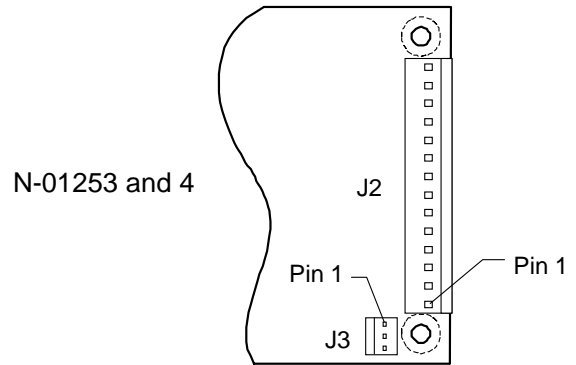

Figure 2 N-01253 and 4 Pinout

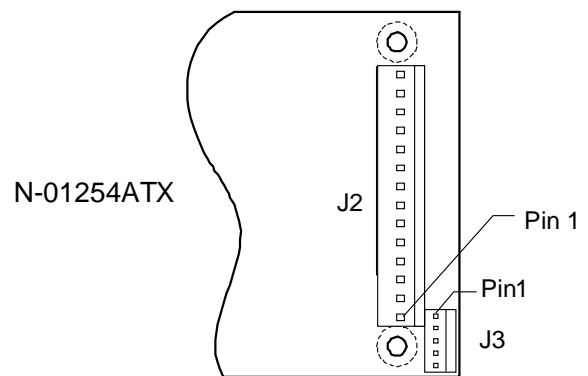

Figure 3 N-01254ATX Pinout

Pin	N-01251 - 5V and 3V3
J2-1	V1 (+ Output)
J2-2	V1 (+ Output)
J2-3	V1 (+ Output)
J2-4	V1 (+ Output)
J2-5	V1 (+ Output)
J2-6	DC RETURN (0V)
J2-7	DC RETURN (0V)
J2-8	DC RETURN (0V)
J2-9	DC RETURN (0V)
J2-10	DC RETURN (0V)
J3-1	Current Share
J3-2	0V Sense (-)
J3-3	V1 Sense (+)
J3-4	PS_OK
J3-5	Power Good
J4-1	+12V AUX (Fan)
J4-2	DC RETURN (0V)

Table 7 N-01254 -2 & -9 Pinout

Pin	N-01251 (12 – 48V)
J2-1	V1 (+ Output)
J2-2	V1 (+ Output)
J2-3	V1 (+ Output)
J2-4	DC RETURN (0V)
J2-5	DC RETURN (0V)
J2-6	DC RETURN (0V)
J3-1	DC RETURN (0V)
J3-2	0V Sense (-)
J3-3	V1 Sense (+)
J3-4	Current Share
J3-5	Power Good
J3-6	PS_OK
J4-1	12V AUX (+) (Fan)
J4-2	12V AUX (-) (Fan)

Table 8 N-01251 (12V – 48V) Pinout

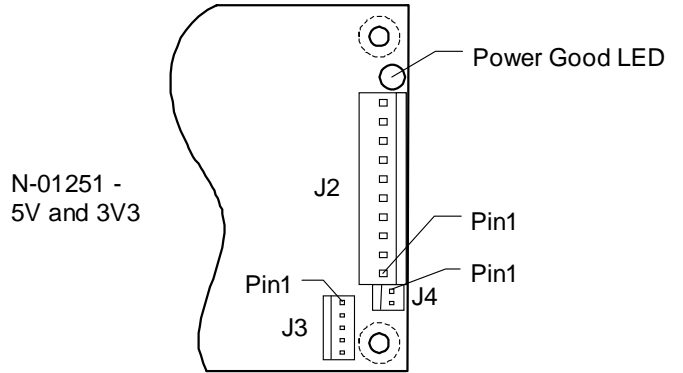

Figure 4 N-01251 - 5V and 3V3 Pinout

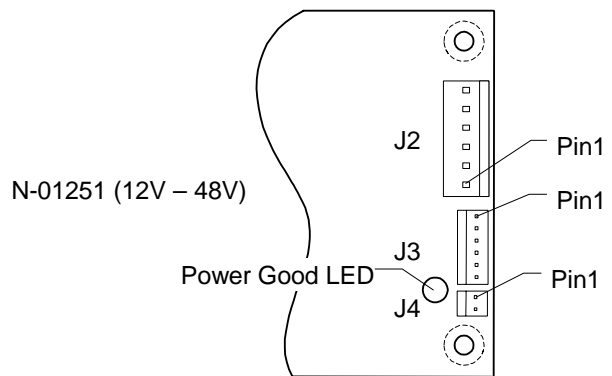

Figure 5 N-01251 (12V – 48V) Pinout

Remote Sense

Remote sense utilizes additional voltage sense wires at the load end of the output cable to determine the output voltage at the load instead of at the power supply. The N-0125X can compensate for up to 0.2V wiring drops in all models except N-01251 12V through N-01251 48V where it can compensate for up to 0.5V of wiring loss.

V1 is the only output that can utilize remote sense. Both the positive outputs and DC returns can be sensed separately in all models except the N-01253 that can only sense the DC return line. When remote sensing is not required, the V1 output voltage accuracy can be improved slightly by connecting the remote sense inputs to the V1 output at the power supply as shown in the Local V1 Sense figures below. The power supply requires no modification to enable local or remote sensing – simply connect the V1 output as shown in the following diagrams:

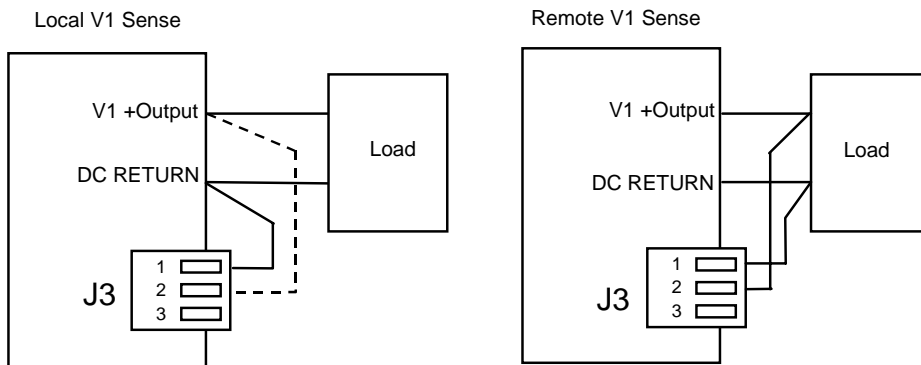

Figure 6 Remote Sensing Wiring: N-01254 (033), N-01254ATX, N-01254 (025) and N-01253

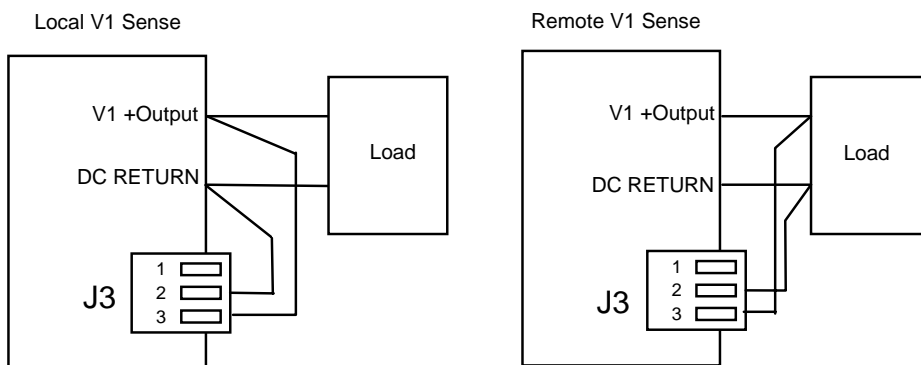

Figure 7 Remote Sensing Wiring: N-01251

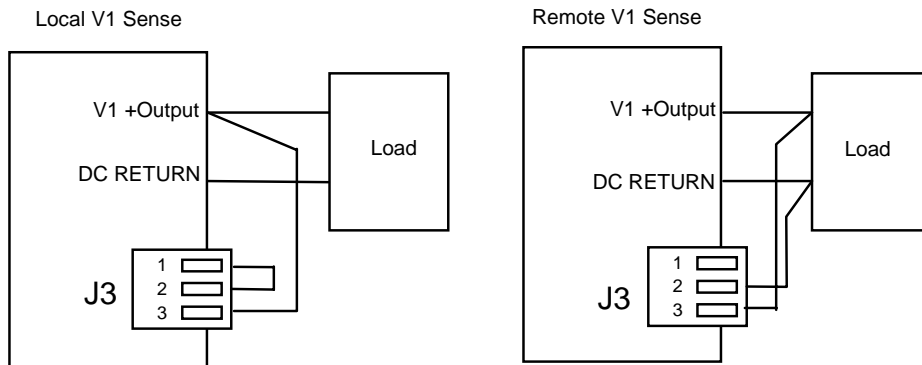

Figure 8 Remote Sensing Wiring: N-01251 (5V – 48V)

Current Sharing with Multiple Power Supplies Wired in Parallel

Two, three or four N-01251 power supplies (must all be the same model) may be connected in parallel to provide higher output power. They can also be used in a N+1 configuration to provide higher output power and greater reliability. Each model has a built-in output OR-ing diode (or MOSFET) and a Current Share signal for parallel operation.

A single-wire current sharing signal forces the parallel power supplies to share the load without the need for external OR-ing diodes (provided internally). In the event of a power supply failure, the remaining power supplies will drive the load current without interruption. The output power available equals the sum of the operating power supplies.

The Current Share signal of each supply operating in parallel must be connected together. Power sharing does not require the 0V Sense signals be connected together, but the sharing accuracy may not meet published specification unless they are also connected together.

Power Good signals may be wire ORed together, but this is not recommended, as a failing power supply will pull the signal low. They should be monitored individually by the user's system.

Power Good Signal/PS_OK Signal

The Power Good (PG) Signal provides a high logic level to indicate that sufficient time has expired for the DC outputs to be within their regulation limits and that sufficient mains energy is stored by the power supply to ensure continuous power operation within specification for the duration of the hold-up time. When the AC mains power is removed for a period longer than 20ms, the Power Good Signal transitions to a low logic level. The PS_OK signal is the logical complement of the Power Good signal and both signals are driven by open-collector transistors. N-01253 and N-1254 models add a TTL-compatible pullup resistor on just the Power Good output. The electrical specifications for the Power Good and PS_OK outputs are described in Table 9.

Signal Type	TTL Compatible
Low Logic Level	<0.4 V when sinking 4 mA
High Logic Level	Open Collector Output (see next)
Power Good Pull-up Resistor	TTL-compatible pull-up only on N-01253 and 4 models
Power On Delay	Between 100 and 500ms after V1 outputs reaches regulation
Power Down Warning	>2 mS before V1 reaches minimum regulated output
Rise Time	<50 μ S from 10% to 90% point.
PS_OK	Logical complement of Power Good signal. Open collector output without a pull-up resistor
PS_ON (input)	Operate < 0.8V, Standby > 2.0V, Load: 1.0 K pull-up to +5 V

Table 9 N-01254 Status and Control Signal Specifications

Power Good LED

A green LED on N-01251 models illuminates whenever the Power Good signal is true (high). The locations of the Power Good LEDs are shown in Figure 4 and Figure 5.

Powerstax plc.
Unit B5, Armstrong Mall, Southwood Business Park, Farnborough, Hants.
ENGLAND. GU14 0NR
Tel: +44 (0) 1252 407800 Fax: +44 (0) 1252 407810
E-mail: sales@powerstaxplc.com **Website:** www.powerstaxplc.com

