

Input Ranges :

10-75 VDC

Output Voltage:

Single Output

3.3V - 48V

Dual Output

+5.0V/+3.3V

Triple Output

+5.0V/+3.3V/+13V,

+5V/±15V

Output Power:

13 W

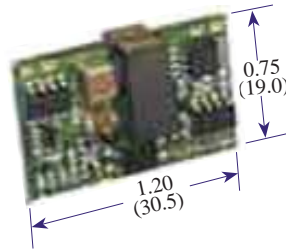

Open Frame (Horizontal Mount)
(0.72"W x 1.17"L x 0.35"H)



Metal Case (Horizontal Mount)
(0.80"W x 1.25"L x 0.40"H)

FEATURES

General:

- Small footprint : 0.75" x 1.20"
- Output power : 13 watts
- Input Voltage from 10 to 75Vdc
- 2:1 & 3:1 Input Voltage Range
- Open frame or Encapsulated
- Integral PCB transformer
- High conversion efficiency to 85%
- Line & load regulation to ±1.0%
- Fixed operating frequency

Protection:

- Output over-load protection
- Hiccup mode short circuit protection
- Input under-voltage lock-out

Control:

- Enable (On/Off) Control
- Output Voltage Trim

Isolation:

- Isolation Voltage > 2250V

APPLICATIONS

- PoE (Power over Ethernet)
- Distributed Power Systems
- Workstations
- Computer Equipment
- Communications Equipment

The **CH** series is a family of 13W DC-DC converters with high power density, high efficiency, and high reliability. It provides 13W output in a 0.75" x 1.20" footprint. The wide input range (2:1, 3:1) is ideal for battery or unregulated input applications.

Integral PCB transformer / inductor is used for all models in this series. This new design technique has greatly improved the magnetic coupling, reduced switching spike and provided performance consistency. It also streamlines the production process by completely eliminating the hand-wind magnetic assembly process from production lines.

CH series provides the most extensive protection to safeguard both the power converter and the load. It includes output over-voltage protection, over-current protection, hiccup mode indefinite short circuit protection and under-voltage lockout. Over-current inception point is set at about 115% of rated load. Hiccup mode cycles at 28mSec period with 3mSec on and 25mSec off.

CH series features low output noise, very tight line and load regulation, and high efficiency. There is no external capacitor requirement for normal operation. Output trim pin is standard for single and dual output.

TABLE OF CONTENTS :

General Specifications	2
Single Output	4
Dual Output.....	6
Triple Output.....	8

1. Absolute Maximum Ratings

Stresses in excess of the absolute maximum ratings can cause performance degradation, adversely effect longterm reliability, and cause permanent damage to the device.

Parameter	Conditions / Description	Min	Max	Units
Input Voltage				
Continuous	12	-0.3	22	Vdc
	24	-0.3	38	Vdc
	48	-0.3	78	Vdc
	30	-0.3	32	Vdc
	60	-0.3	62	Vdc
Transient (100mSec.)	12	-0.3	24	Vdc
	24	-0.3	40	Vdc
	48	-0.3	80	Vdc
	30	-0.3	34	Vdc
	60	-0.3	64	Vdc
Operating Temperature	All models, base plate temperature	-40	+105	°C
Storage Temperature	Ambient	-55	+125	°C
Isolation Voltage	Input to Output		+2500	Vdc

2. Input Specifications

Parameter	Conditions / Description	Min	Nom	Max	Units
Input Voltage					
Voltage Range (Continuous)	12	10	12	20	Vdc
	24	18	24	36	Vdc
	48	36	48	75	Vdc
	30	10	24	30	Vdc
	60	20	48	60	Vdc
Under-Voltage Lockout (UVLO)					
Turn-On Threshold (Ramping Up)	12		9.7		Vdc
	24		17.7		Vdc
	48		35		Vdc
	30		9.7		Vdc
	60		17.7		Vdc
Turn-Off Threshold (Ramping Down)	12		9.5		Vdc
	24		16		Vdc
	48		33		Vdc
	30		9.2		Vdc
	60		16		Vdc

3. Enable (On-Off Control)

Parameter	Conditions / Description	Min	Nom	Max	Units
Enable Pin					
Open Circuit Voltage			10		Vdc
Source/Sink Current				1	mA
Positive Logic	Standard				
On-Control	Logic High or Floating	2.5		10	Vdc
Off-Control		-0.5		1.8	Vdc
Negative Logic	Not Available				

* Enable pin can be left floating if not used.

4. Isolation Specifications

Parameter	Conditions / Description	Min	Nom	Max	Units
Isolation Voltage					
Input to Output		2250			Vdc
I/O to Case		1125			Vdc
Isolation Resistance	Input to Output	10			MΩ
Isolation Capacitance	Input to Output		3		nF

5. Output Specifications

Parameter	Conditions / Description	Min	Nom	Max	Units
Voltage Accuracy	Please see table				%
Output Current	Please see table				Adc
Output Trim			±10		%Vout
Over Voltage Protection				120	%Vdc
Line Regulation			±0.2		%Vout
Load Regulation			±0.5		%Vout
Transient Response	50% ± 25% step load change		400		µSec.
Ripple & Noise	Please see table				mVp-p
Switching Frequency			200		KHz

6. Output Trim

Parameter	Conditions / Description	Min	Nom	Max	Units
Positive Logic	Standard				
Trim-Up	Trim Pin to (-)Output			10	%Vdc
Trim-Down	Trim Pin to (+)Output	5			%Vdc
Negative Logic	Not Available				

* Trim pin can be left floating if not used.

7. Environmental and Mechanical Specifications

Parameter	Conditions / Description	Min	Nom	Max	Units
Operating Temperature	PCB Temperature				
Standard		-25		+100	°C
Extended		-55		+100	°C
Storage Temperature		-55		+125	°C
Temperature Coefficient				±0.02	%/°C
Shock	Halfsine wave, 3 axes	50			g
Sinusoidal Vibration	GR-63-CORE, Section 5.4.2	1			g
Humidity	Relative Humidity, Non-Condensing			95	%R.H.
Weight					
Open Frame			0.3(8)		Oz(g)
Encapsulated			1.0(28)		Oz(g)
MTBF (calculated)	Bellcore TR-NWT-000332 method 1 - parts count	1			MHrs

8. Protections

Parameter	Conditions / Description	Min	Nom	Max	Units
Over-Load Protection					
Type	Current-Mode, Pulse by Pulse Current Limit				
Threshold	% Rated Load		120		%
Short-Circuit Protection					
Type	Hiccup Mode, Non-Latching, Auto-Recovery				
Threshold	Short-Circuit Resistance			65	mΩ
Over-Temperature Protection					
Type	Non-Latching, Auto-Recovery				
Threshold	PCB Temperature		TBD		°C
Hysteresis			TBD		°C
Over-Voltage Protection	Not Available				

INPUT			OUTPUT								Short Circuit Protection	Over Temp. Shutdown /Recover	EFF. (typ.)	MODEL NO.
Nominal (Range)	Under Voltage Lockout (typ.)		Voltage (V)			Current (A)		Ripple & Noise						
	On	Off	Set Point	Min.*	Max.*	Min.	Max.	Peak-Peak	R.M.S.					
12 (10-20)	9.7	9.2	13W	3.30	3.20	3.40	0	4.0	75mV	15mV	Hiccup Mode Indefinite	TBD	80%	CH13S12033
				5.00	4.90	5.10	0	2.6	75mV	15mV			82%	CH13S1205
				7.50	7.40	7.60	0.18	1.8	80mV	20mV			81%	CH13S12075
				9.00	8.90	9.10	0.15	1.5	90mV	20mV			81%	CH13S1209
				12.0	11.88	12.12	0.10	1.0	100mV	25mV			81%	CH13S1212
				15.0	14.85	15.15	0.08	0.87	120mV	30mV			81%	CH13S1215
				24.0	23.76	24.24	0.05	0.54	200mV	40mV			81%	CH13S1224
				28.0	27.72	28.28	0.04	0.46	240mV	50mV			81%	CH13S1228
				32.0	31.70	32.30	0.04	0.40	280mV	60mV			81%	CH13S1232
				48.0	47.50	48.50	0.03	0.27	400mV	80mV			81%	CH13S1248
24 (18-36)	17.7	16.6	13W	3.30	3.20	3.40	0	4.0	75mV	15mV	Hiccup Mode Indefinite	TBD	82%	CH13S24033
				5.00	4.90	5.10	0	2.6	75mV	15mV			84%	CH13S2405
				7.50	7.40	7.60	0.18	1.8	80mV	20mV			83%	CH13S24075
				9.00	8.90	9.10	0.15	1.5	90mV	20mV			83%	CH13S2409
				12.0	11.88	12.12	0.10	1.0	100mV	25mV			83%	CH13S2412
				15.0	14.85	15.15	0.08	0.87	120mV	30mV			83%	CH13S2415
				24.0	23.76	24.24	0.05	0.54	200mV	40mV			83%	CH13S2424
				28.0	27.72	28.28	0.04	0.46	240mV	50mV			83%	CH13S2428
				32.0	31.70	32.30	0.03	0.40	280mV	60mV			83%	CH13S2432
				48.0	47.50	48.50	0.03	0.27	400mV	80mV			83%	CH13S2448
48 (36-75)	35	33	13W	3.30	3.20	3.40	0	4.0	75mV	15mV	Hiccup Mode Indefinite	TBD	82%	CH13S48033
				5.00	4.90	5.10	0	2.6	75mV	15mV			84%	CH13S4805
				7.50	7.40	7.60	0.18	1.8	80mV	20mV			83%	CH13S48075
				9.00	8.90	9.10	0.15	1.5	90mV	20mV			83%	CH13S4809
				12.0	11.88	12.12	0.10	1.0	100mV	25mV			83%	CH13S4812
				15.0	14.85	15.15	0.08	0.87	120mV	30mV			83%	CH13S4815
				24.0	23.76	24.24	0.05	0.54	200mV	40mV			83%	CH13S4824
				28.0	27.72	28.28	0.04	0.46	240mV	50mV			83%	CH13S4828
				32.0	31.70	32.30	0.04	0.40	280mV	60mV			83%	CH13S4832
				48.0	47.50	48.50	0.03	0.27	400mV	80mV			83%	CH13S4848
30 (10-30)	9.7	9.2	13W	3.30	3.20	3.40	0	4.0	75mV	15mV	Hiccup Mode Indefinite	TBD	80%	CH13S30033
				5.00	4.90	5.10	0	2.6	75mV	15mV			82%	CH13S3005
				7.50	7.40	7.60	0.18	1.8	80mV	20mV			81%	CH13S30075
				9.00	8.90	9.10	0.15	1.5	90mV	20mV			81%	CH13S3009
				12.0	11.88	12.12	0.10	1.0	100mV	25mV			81%	CH13S3012
				15.0	14.85	15.15	0.08	0.87	120mV	30mV			81%	CH13S3015
				24.0	23.76	24.24	0.05	0.54	200mV	40mV			81%	CH13S3024
				28.0	27.72	28.28	0.04	0.46	240mV	50mV			81%	CH13S3028
				32.0	31.70	32.30	0.04	0.40	280mV	60mV			81%	CH13S3032
				48.0	47.50	48.50	0.03	0.27	400mV	80mV			81%	CH13S3048
60 (20-60)	17.7	16.6	13W	3.30	3.20	3.40	0	4.0	75mV	15mV	Hiccup Mode Indefinite	TBD	80%	CH13S60033
				5.00	4.90	5.10	0	2.6	75mV	15mV			82%	CH13S6005
				7.50	7.40	7.60	0.18	1.8	80mV	20mV			81%	CH13S60075
				9.00	8.90	9.10	0.15	1.5	90mV	20mV			81%	CH13S6009
				12.0	11.88	12.12	0.10	1.0	100mV	25mV			81%	CH13S6012
				15.0	14.85	15.15	0.08	0.87	120mV	30mV			81%	CH13S6015
				24.0	23.76	24.24	0.05	0.54	200mV	40mV			81%	CH13S6024
				28.0	27.72	28.28	0.04	0.46	240mV	50mV			81%	CH13S6028
				32.0	31.70	32.30	0.04	0.40	280mV	60mV			81%	CH13S6032
				48.0	47.50	48.50	0.03	0.27	400mV	80mV			81%	CH13S6048

* Combined Line, Load & Cross Regulation.

Product Numbering System & Selection Guide

CH	13	S	24	033	C
Series No.	Output Power	No Output	Input Voltage	Output Voltage	Options
CH	13 : 13W	S : Single	12 : 10-20V	018 : 1.8V	C : -55°C Operation
			24 : 18-36V	025 : 2.5V	MC : Metal Case
			48 : 36-75V	...	
			30 : 10-30V	32 : 32V	
			60 : 20-60V	48 : 48V	

BLOCK DIAGRAM

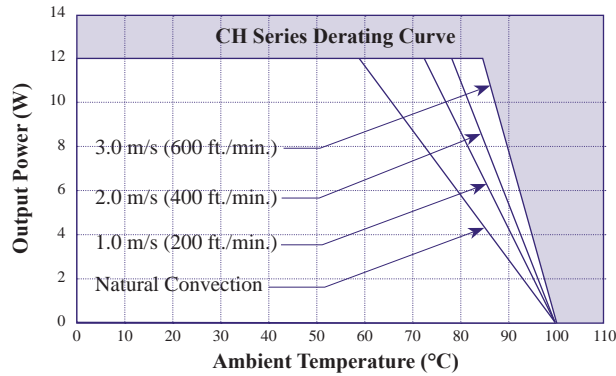
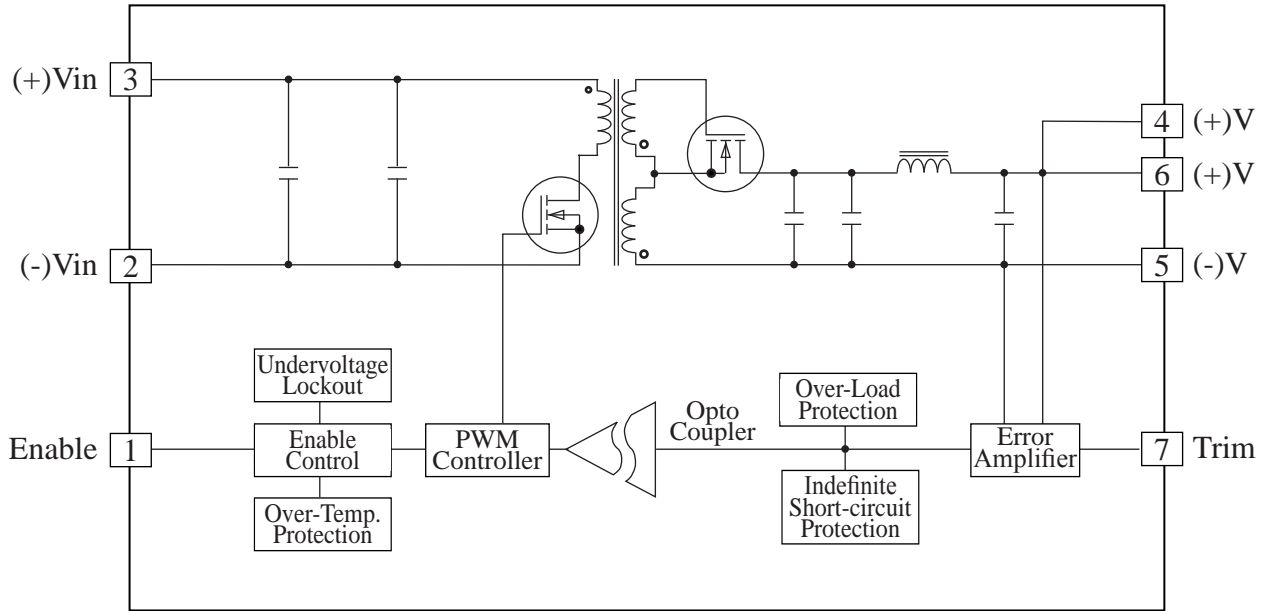

Open Frame (Standard)

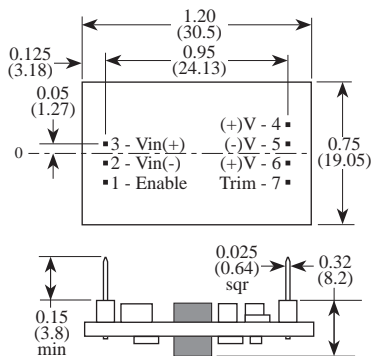

Encapsulated (Suffix - MC)

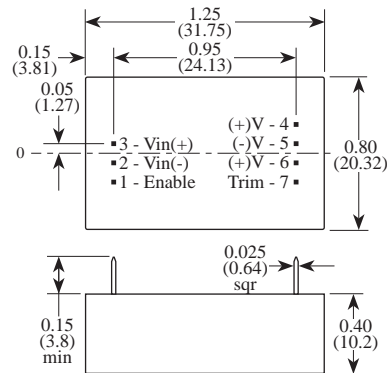

INPUT			OUTPUT											EFF. (typ.)	MODEL NO.	
Nominal (Range)	Under Voltage Lockout (typ.)		Max. Output Power	Voltage (V)				Current (A)			Ripple & Noise		Short Circuit Protection			
	On	Off		#	Set Point	Min.*	Max.*	#	Min.	Max.	Peak-Peak	R.M.S.				
12 (10 - 20)	9.5	9.2	13W	+5.0	+V1	+5.00	+4.85	+5.15	+I1	0.2	2.6	75mV	15mV	Hiccup Mode Indefinite	82%	CH13D1205-033
				+3.3	+V2	+3.30	+3.20	+3.40	+I2	0.4	4.0	75mV	15mV			
24 (18 - 36)	17	16	13W	+5.0	+V1	+5.00	+4.85	+5.15	+I1	0.2	2.6	75mV	15mV		84%	CH13D2405-033
				+3.3	+V2	+3.30	+3.20	+3.40	+I2	0.4	4.0	75mV	15mV			
48 (36 - 75)	34	33	13W	+5.0	+V1	+5.00	+4.85	+5.15	+I1	0.2	2.6	75mV	15mV		85%	CH13D4805-033
				+3.3	+V2	+3.30	+3.20	+3.40	+I2	0.4	4.0	75mV	15mV			
30 (10 - 30)	9.5	9.2	13W	+5.0	+V1	+5.00	+4.85	+5.15	+I1	0.2	2.6	75mV	15mV	80%	CH13D3005-033	
				+3.3	+V2	+3.30	+3.20	+3.40	+I2	0.4	4.0	75mV	15mV			
60 (18 - 60)	17	16	13W	+5.0	+V1	+5.00	+4.85	+5.15	+I1	0.2	2.6	75mV	15mV	83%	CH13D6005-033	
				+3.3	+V2	+3.30	+3.20	+3.40	+I2	0.4	4.0	75mV	15mV			

* Combined Line & Load Regulation.

Open Frame (Standard)

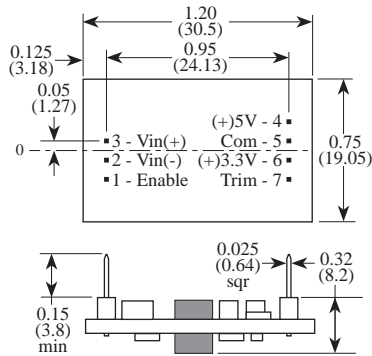

Encapsulated (Suffix - MC)

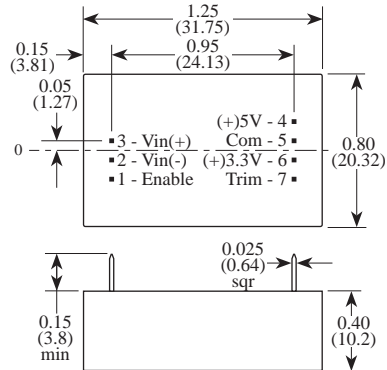

Product Numbering System & Selection Guide

Series No.	Output Power	No Output	Input Voltage	+V1 Output	+V2 Output	Options
CH	13 : 13W	D : Dual	12 : 10-20V 24 : 18-36V 48 : 36-75V 30 : 10-30V 60 : 20-60V	05 : 5.0V	033 : 3.3V	C : -55°C Operation MC : Metal Case

BLOCK DIAGRAM (+5V, +3.3V)

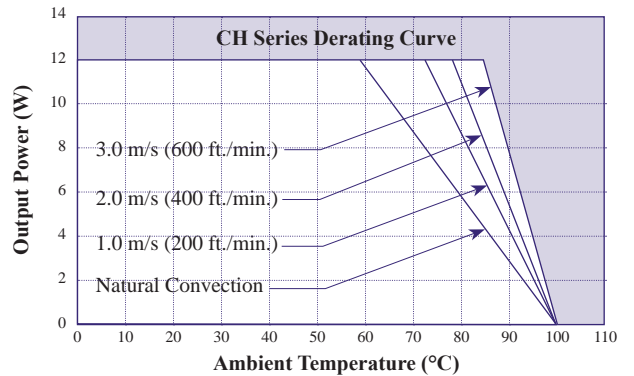
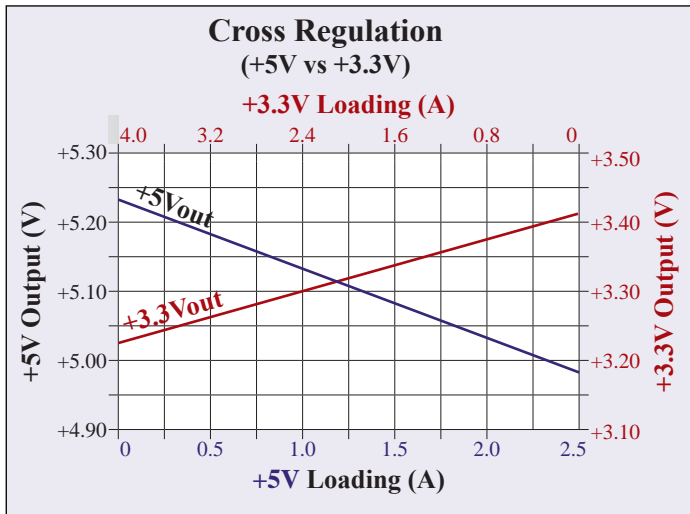
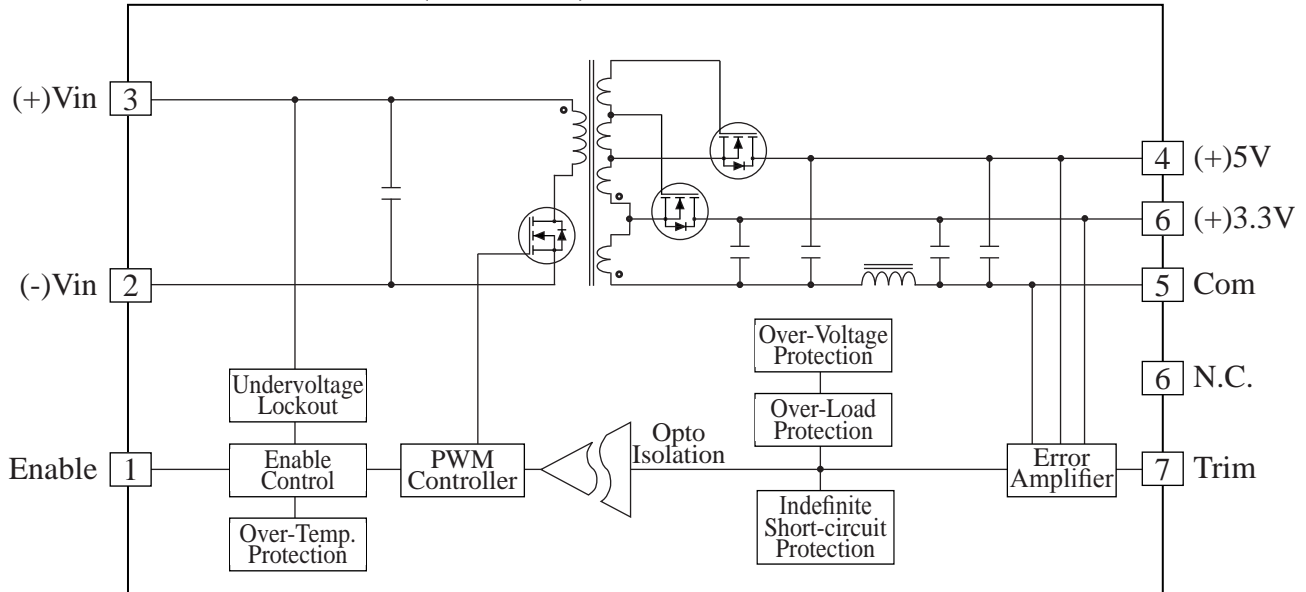

Derating Curve

INPUT				OUTPUT										Short Circuit Protection	EFF. (typ.)	MODEL NO.	
Nominal (Range)	Under Voltage Lockout (typ.)		Max. Output Power	Voltage (V)						Current (A)			Ripple & Noise				
	On	Off		#	Set Point	Min.*	Max.*	#	Min.	Max.	Peak-Peak	R.M.S.					
12 (10 - 20)	9.7	9.2	13W	+5.0	+V1	+5.00	+4.90	+5.10	+I1	0.2	2.0	75mV	15mV	Hiccup Mode Indefinite	82%	CH13T1205033-13	
				+3.30	+V2	+3.30	+3.20	+3.40	+I2	0.4	4.0	75mV	15mV				
				+13	+V3	+13.2	+12.5	+14.5	+I3	0.05	0.8	150mV	40mV				
			13W	+5.0	+V1	+5.00	+4.90	+5.10	+I1	0.2	2.0	75mV	15mV				
				±15	+V2	+15.0	+14.0	+16.0	+I2	0.05	0.5	150mV	50mV				
				-V3	-15.0	-14.0	-16.0	+I3	0.05	0.5	150mV	50mV					
24 (18 - 36)	17	16	13W	+5.0	+V1	+5.00	+4.90	+5.10	+I1	0.2	2.6	75mV	15mV		84%	CH13T240503-13	
				+3.30	+V2	+3.30	+3.20	+3.40	+I2	0.4	4.8	75mV	15mV				
				+13	+V3	+13.2	+12.5	+14.5	+I3	0.05	0.8	150mV	40mV				
			13W	+5.0	+V1	+5.00	+4.90	+5.10	+I1	0.2	2.6	75mV	20mV				
				±15	+V2	+15.0	+14.0	+16.0	+I2	0.05	0.5	150mV	50mV				
				-V3	-15.0	-14.0	-16.0	+I3	0.05	0.5	150mV	50mV					
48 (36 - 75)	34	33	13W	+5.0	+V1	+5.00	+4.90	+5.10	+I1	0.2	2.6	75mV	15mV		84%	CH13T480503-13	
				+3.30	+V2	+3.30	+3.20	+3.40	+I2	0.4	4.8	75mV	15mV				
				+13	+V3	+13.2	+12.5	+14.5	+I3	0.05	0.8	150mV	40mV				
			13W	+5.0	+V1	+5.00	+4.90	+5.10	+I1	0.2	2.6	75mV	20mV				
				±15	+V2	+15.0	+14.0	+16.0	+I2	0.05	0.5	150mV	50mV				
				-V3	-15.0	-14.0	-16.0	+I3	0.05	0.5	150mV	50mV					
30 (10 - 30)	9.7	9.2	13W	+5.0	+V1	+5.00	+4.90	+5.10	+I1	0.2	2.6	75mV	15mV	81%	CH13T300503-13		
				+3.30	+V2	+3.30	+3.20	+3.40	+I2	0.4	4.8	75mV	15mV				
				+13	+V3	+13.2	+12.5	+14.5	+I3	0.05	0.8	150mV	40mV				
			13W	+5.0	+V1	+5.00	+4.90	+5.10	+I1	0.2	2.6	75mV	20mV				
				±15	+V2	+15.0	+14.0	+16.0	+I2	0.05	0.5	150mV	50mV				
				-V3	-15.0	-14.0	-16.0	+I3	0.05	0.5	150mV	50mV					
60 (18 - 60)	17	16	13W	+5.0	+V1	+5.00	+4.90	+5.10	+I1	0.2	2.6	75mV	15mV	83%	CH13T600503-13		
				+3.30	+V2	+3.30	+3.20	+3.40	+I2	0.4	4.8	75mV	15mV				
				+13	+V3	+13.2	+12.5	+14.5	+I3	0.05	0.8	150mV	40mV				
			13W	+5.0	+V1	+5.00	+4.90	+5.10	+I1	0.2	2.6	75mV	20mV				
				±15	+V2	+15.0	+14.0	+16.0	+I2	0.05	0.5	150mV	50mV				
				-V3	-15.0	-14.0	-16.0	+I3	0.05	0.5	150mV	50mV					

* Combined Line and Load Regulation.

Open Frame (Standard)

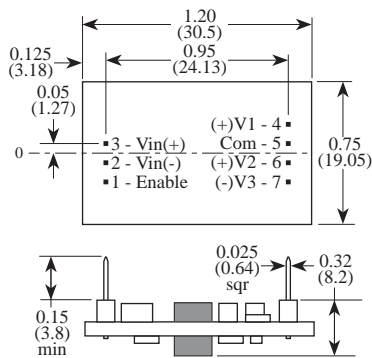

Encapsulated (Suffix - MC)

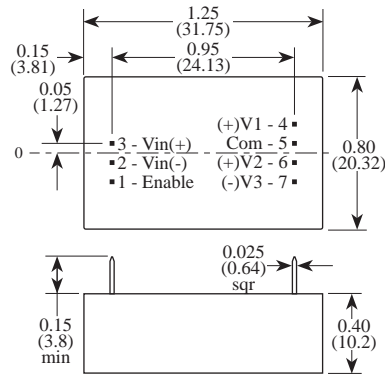

Product Numbering System & Selection Guide

CH	13	T	24	05	-	033	-	13	MC
Series No.	Output Power	No Output		Input Voltage		V1 Output	V2 Output	V3 Output	Options
CH	13: 13W	T: Triple	12: 10-20V	05: 5.0V	033: 3.3V	13: 13V	C: Extended Temp.	MC: Encapsulated	
			24: 18-36V						
			48: 36-75V	05: 5.0V	13: ±13V				
			30: 10-30V						
			60: 20-60V						

BLOCK DIAGRAM (+5V, +3.3V, +13V)

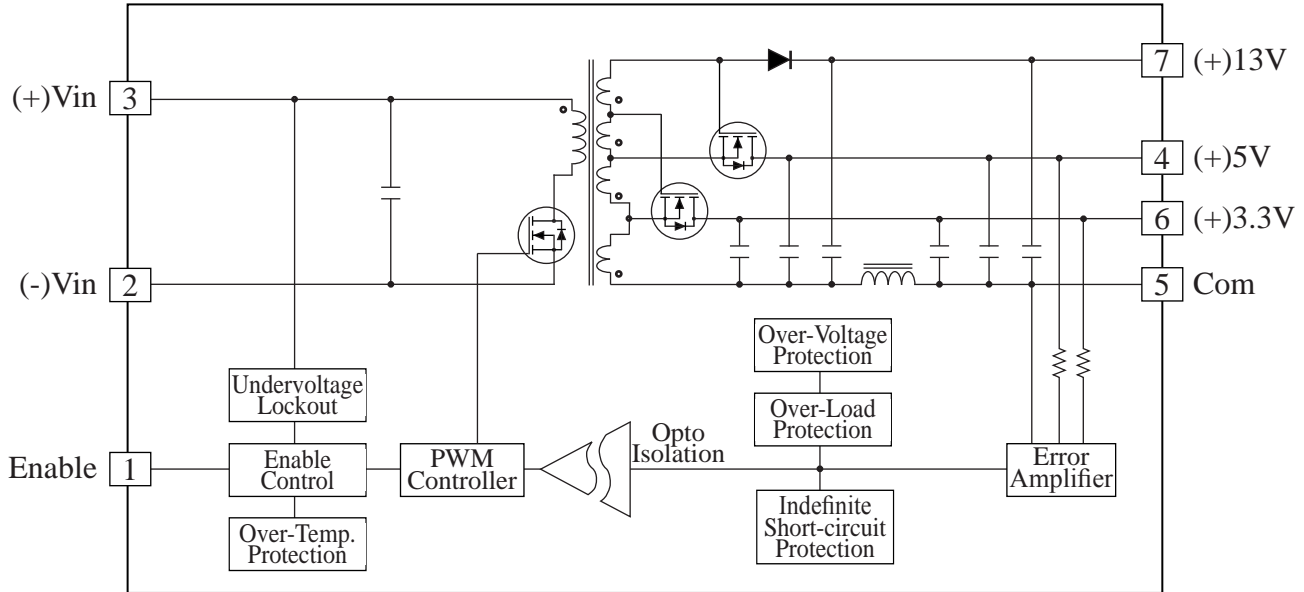

BLOCK DIAGRAM (+5V, ±15V)

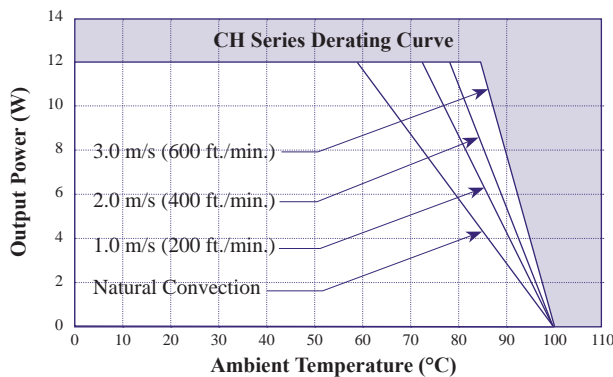
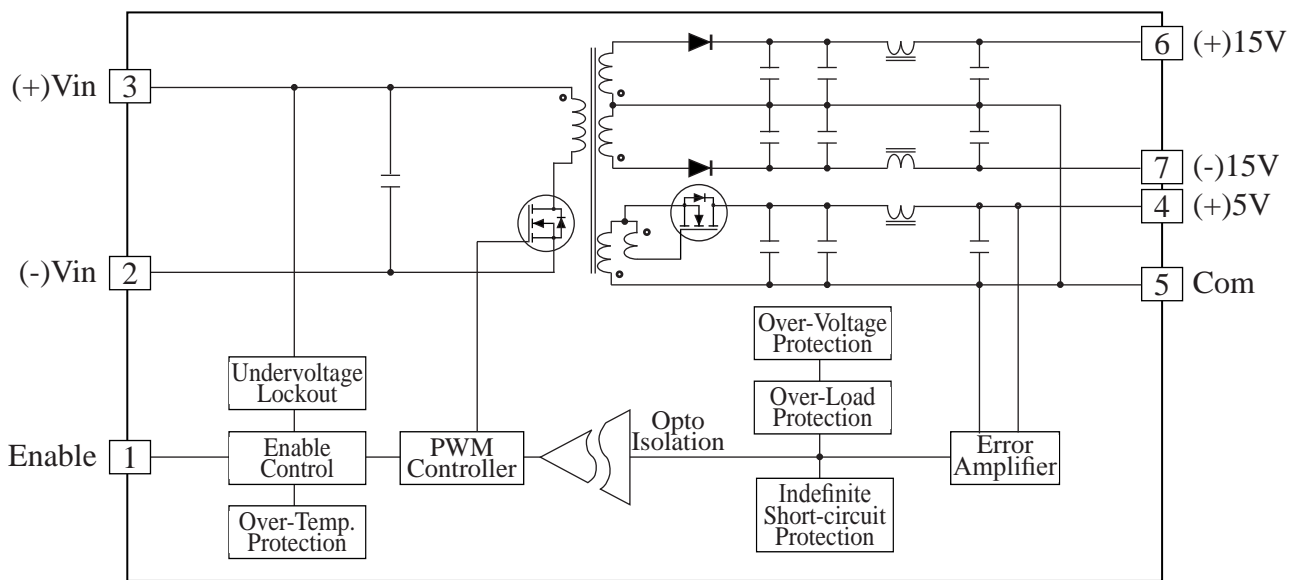

Derating Curve

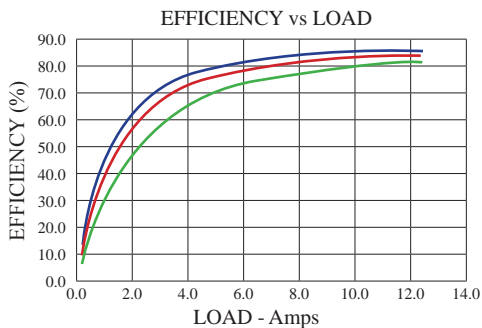
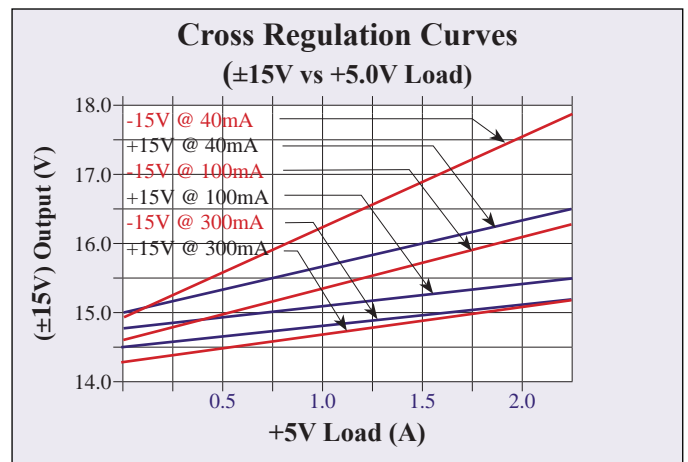
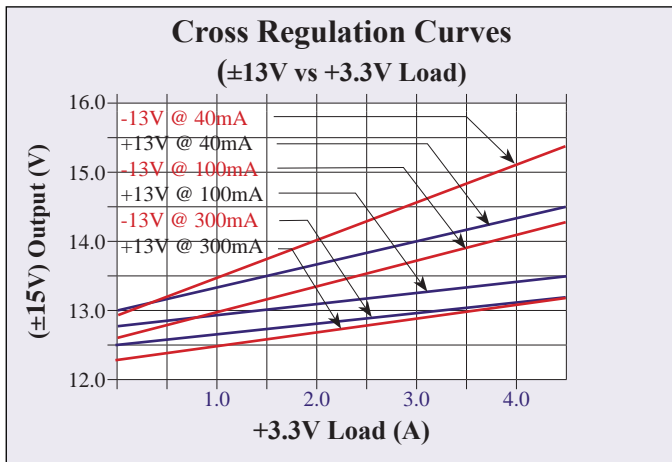
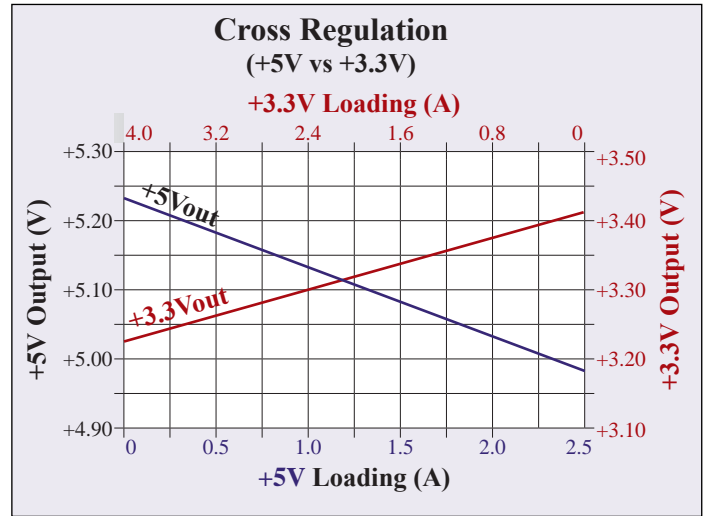
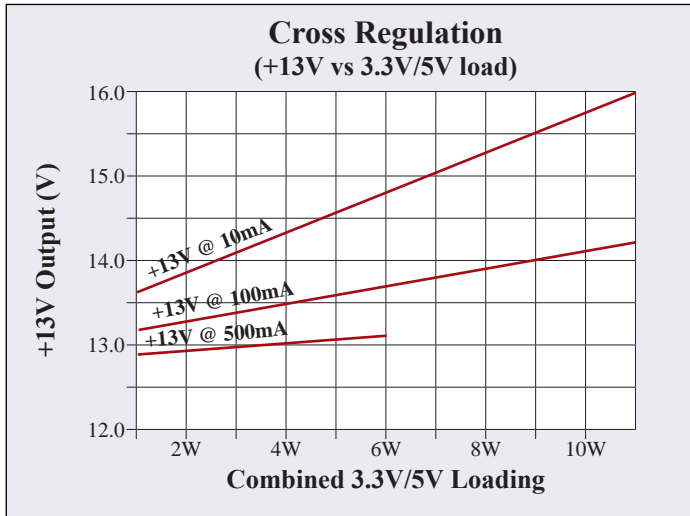

CH13T2405-033-13