

Input Voltage

The minimum and maximum input voltage which the converter has been designed to operate and within this voltage range the converter has been tested and met its specifications.

Input voltage ranges of ACON DC-DC converters are as follows.

Input Voltage Designator	Input Voltage Range (Vdc)
12	9 ~ 18 or 10 ~ 20
24	18 ~ 36
24W	10 ~ 36
30	10 ~ 30
48	36 ~ 75
48W	20 ~ 72 or 18 ~ 75
60	20 ~ 60

Input voltage normally includes the ripple voltage as shown below. The ripple voltage shall be less than the following values.

Input Voltage Designator	Input Ripple Voltage
12	1.0 Vp-p
24	2.0 Vp-p
24W	4.0 Vp-p
30	4.0 Vp-p
48	4.0 Vp-p
48W	4.0 Vp-p
60	4.0 Vp-p

When ripple voltage exceeds the above value, the out ripple voltage may become larger. The peak of input voltage wave shall be within the input voltage range.

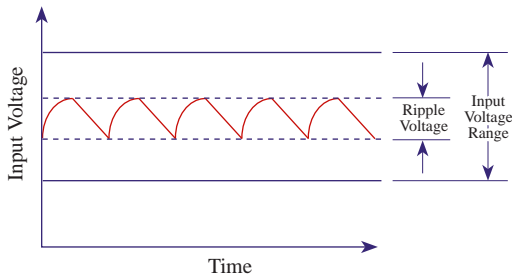

Input Fusing

In order to comply with safety requirements, the user must provide a fuse in the input line. Fuses should also be used if the possibility of input polarity reversals exists. The fuse will cut off input power in the event of a catastrophic failure within the converter.

The fuse should have the current rating capable of withstanding the turn on inrush current but it should also be fast enough to blow to minimize the damage as much as possible.

It is recommended that the fuse be a slow-blow type with a current rating approximately 200% of the the full load input current to the converter.

Input	Range (Vdc)	25W	50W	150W	200W	300W
12	10 ~ 20	5A	8A	25A	30A	40A
24	18 ~ 36	3A	4A	12A	15A	20A
24W	10 ~ 36	5A	8A	25A	30A	40A
30	10 ~ 30	5A	8A	25A	30A	40A
48	36 ~ 75	1.5A	3A	8A	10A	15A
48W	18 ~ 75	3A	4A	12A	15A	20A
60	20 ~ 60	3A	4A	12A	15A	20A

Reverse Voltage Protection

Input reverse polarity can be protected with a series diode (Figure A) or with a shunt diode (Figure B). A series diode protection is dissipative and is not practical for low input voltage and/or high input current application due to the forward voltage and high power dissipation on the diode. A shunt diode protection is a non-dissipative method, but it requires an input fuse (Figure C). Under input reverse-polarity condition, the internal shunt diode will become forward biased and will draw excess current from the power source.

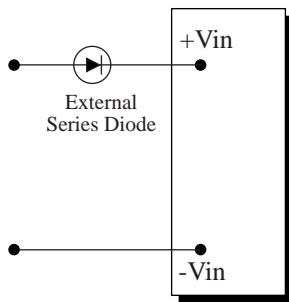

Fig. A

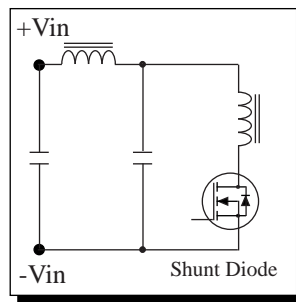

Fig. B

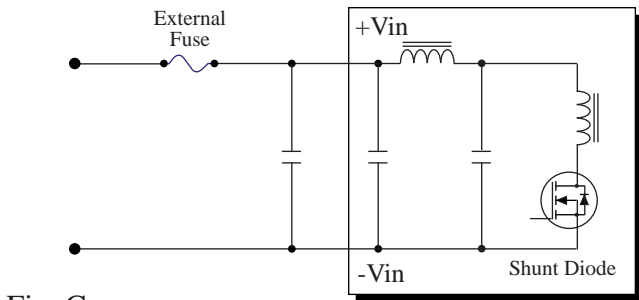
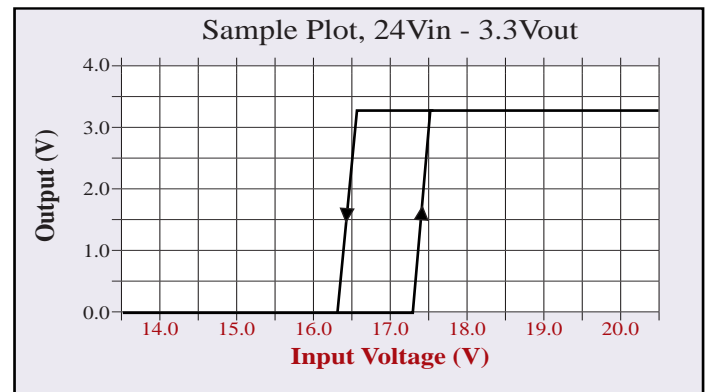

Fig. C

Input Undervoltage Lockout

The converter will shut itself off in the event of the line voltage condition that reach below certain threshold to prevent drawing excessive input current from the power source. The converter will automatically turn back on when the input line reach the turn-on threshold voltage.

The figure below shown that a 3.3Vout converter turns on at about 17.5Vin and and locks out at about 16.5Vin. The built in hysteresis of 1.0V between turn on and lockout threshold prevents the converter output jittering when the input voltage is near the threshold.



Under-Voltage Lockout

Enable (On/Off) Control

The Enable pin allows the power module to be switched on and off electronically. The Enable (On/Off) function is useful for conserving battery power, for pulsed power application or for power up sequencing.

The Enable pin is referenced to the -Vin. It is pulled up internally, so no external voltage source is required. An open collector (or open drain) switch is recommended for the control of the the Enable pin.

When using the Enable pin, make sure that the reference is really the -Vin pin, not ahead of EMI filtering, or remotely from the unit. Optically coupling the control signal and locating the opto coupler directly at the module will avoid any of these problem.

If the Enable pin is not used, it can be left floating (positive logic), or connected to the -Vin pin (negative logic).

Enable :	Positive Logic	Negative Logic
ON - Control	Enable HIGH or FLOAT	Enable LOW
OFF - Control	Enable LOW	Enable HIGH or FLOAT

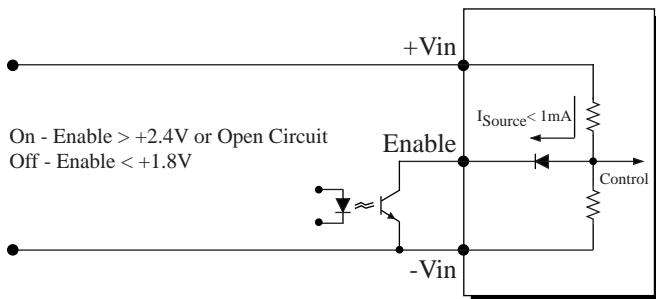

Turn-On Time

This is the time it takes for the output voltage to reach and settle to the specified voltage accuracy when output is fully loaded with resistive load. The input voltage is applied with nominal value.

The converter turn-on time includes the turn-on delay and the rise time. The turn-on delay is due to the primary bias capacitance charging, and the rise time is determined primarily by the soft start characteristic of the PWM control circuit.

Turn-on time is specified separately by Enable to Vout and by Input to Vout (see Figure 9.6).

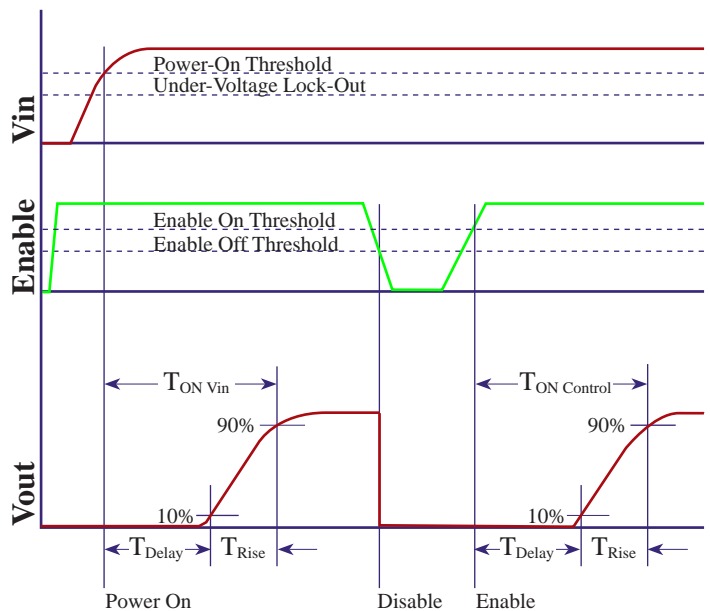

Exclusively distributed by Powerstax

Input Filtering

DC-DC converters by nature generate significant levels of both conducted and radiated noise. There are two types of conducted noise: common mode and differential mode noise. The common mode noise is directly related to the effective parasitic capacitance between the power module input conductors and chassis ground. The differential mode noise is across the input conductors. It is recommended to have some level of EMI suppression to the power module.

Conducted noise on the input power lines can occur as either differential or common-mode noise currents. The required standard for conducted emissions is EN55022 Class A (FCC Part 15).

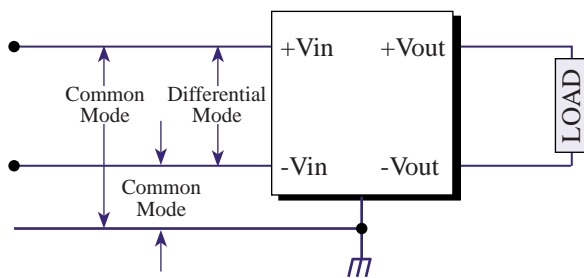

Conducted EMI

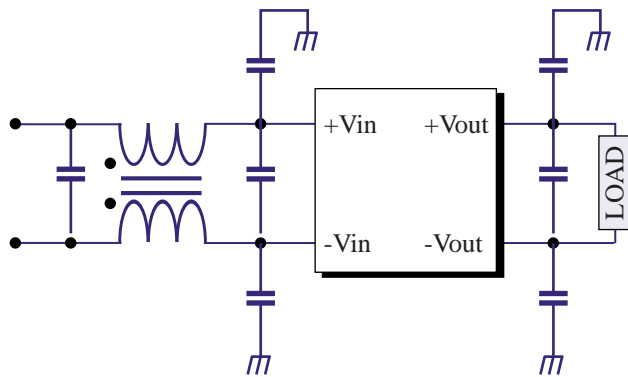

External Common Mode Filter

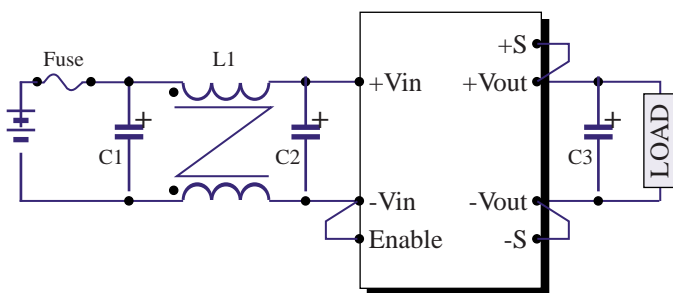

Basic Connection

Input Reflected Ripple Current

Converter is drawing current from input power source only when the input switch is on. This creates a pulsation current flow from the input source. The reflected ripple current is measured as a peak-to-peak current with a current probe over 0 to 20MHz bandwidth. Ripple current can be suppressed by an external Π (pi) filter as shown below.

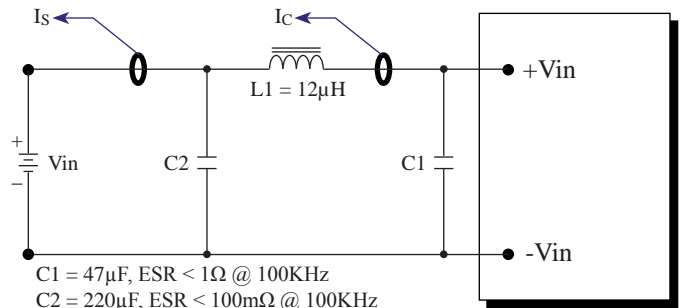

$C1 = 47\mu\text{F}$, $\text{ESR} < 1\Omega @ 100\text{KHz}$
 $C2 = 220\mu\text{F}$, $\text{ESR} < 100\text{m}\Omega @ 100\text{KHz}$
 I_c = Reflected Ripple Current without External LC Filter
 I_s = Reflected Ripple Current with External LC Filter

Input Reflected Ripple Current

Line Regulation

The percent change in output voltage when the input voltage is swung from rated minimum (Low Line) to rated maximum (High Line) while the out is fully loaded.

Load Regulation

The percent change in output voltage when the output load is switched from minimum rated load to maximum rated load.

Cross Regulation

In a multiple output power supply, the percent voltage change at one output caused by the load change on another output. See Figure below.

Transient Response

The time it takes for the output voltage to settle to the specified voltage accuracy after the 25% output load change.

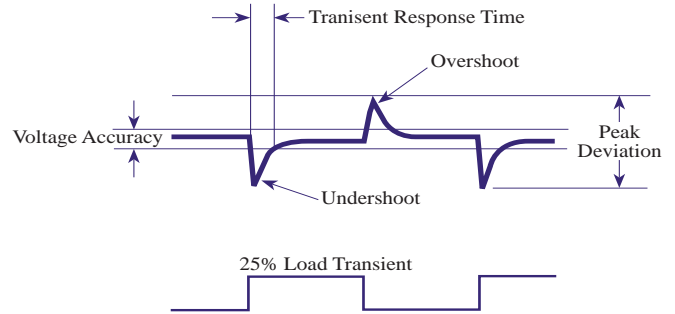

Load Transient

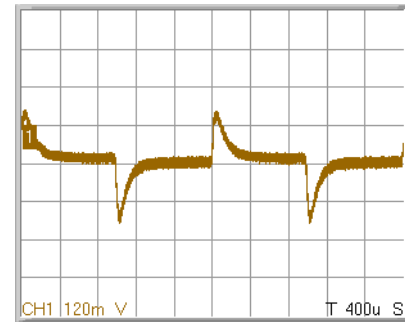
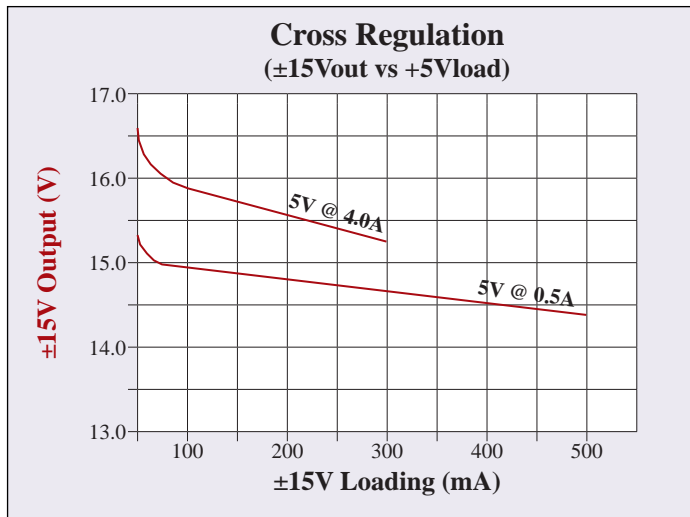

Screen Shot of Load Transient

Remote Sensing

Remote sensing allows the converter to sense the output voltage directly at the point of load and thus automatically compensates the load conductor distribution & contact losses (Fig. a). There is one sense lead for each output terminal, designated +Sense and -Sense. These leads carry very low current compared with the load leads. Internally a resistor is connected between sense terminal and power output terminal. If the remote sense is not used, the sense leads needs to be shorted to their respective output leads (Fig. b).

Care has to be taken when making output connections. If the output terminals should disconnect before the sense lines, the full load current will flow down the sense lines and damage the internal sensing resistors. Be sure to always power down the converter before making any output connections. The maximum compensation voltage for line drop is up to 0.5V

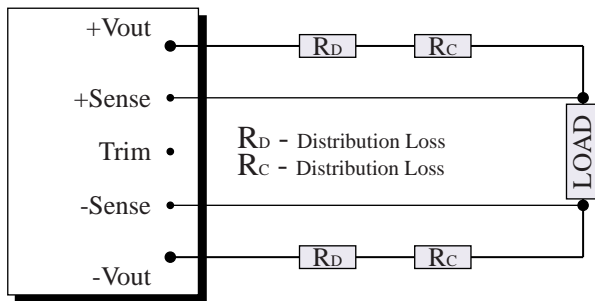

Fig. a Remote Sense Connection

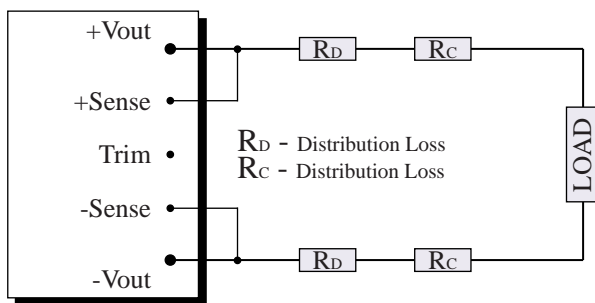

Fig. b Remote Sense is not Used.

Output Ripple & Noise

The output ripple is composed of fundamental frequency ripple and high frequency switching noise spikes. The fundamental switching frequency ripple (or basic ripple) is in the 100KHz to 1MHz range; the high frequency switching noise spike (or switching noise) is in the 10 MHz to 50MHz range. The switching noise is normally specified with 20 MHz bandwidth to include all significant harmonics for the noise spikes.

In the case of switching power supplies and DC-DC converters, the output ripple is composed of fundamental frequency ripple and high frequency switching noise spikes. The fundamental switching frequency ripple (or basic ripple) is in the 100KHz to 1MHz range; the high frequency switching noise spike (or switching noise) is in the 10 MHz to 50MHz range. The switching noise is normally specified with 20 MHz bandwidth to include all significant harmonics for the noise spikes.

The easiest way to measure the output ripple and noise is to use an oscilloscope probe tip and ground ring pressed directly against the power converter output pins, as shown below. This makes the shortest possible connection across the output terminals.

The oscilloscope probe ground clip should never be used in the ripple and noise measurement. The ground clip will not only act as an antenna and pick-up the the radiated high frequency energy, it will introduce the common-mode noise to the measurement as well.

The standard test setup for ripple & noise measurements is shown in Figure 9.9a. A probe socket (Tektronix, P.N. 131.0258-00) is used for the measurements to eliminate noise pickup associated with long ground clip of scope probes.

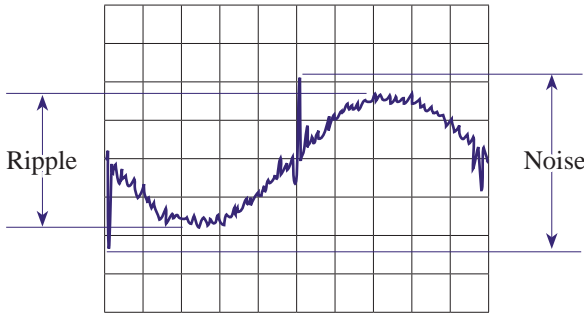

Output Ripple & Noise

Output Voltage Trim

Output voltage can be adjusted up or down with an external resistor. There are positive trim logic and negative trim logic available. For positive logic, the output voltage will increase when an external trimming resistor connected between the Trim and +Vout/+Sense pin. The output voltage will decrease when an external trimming resistor connected between Trim and -Vout/-Sense pin. A multi-turn 20K Ω trim pot can also be used to adjust the output voltage up or down.

Output Trim Logic:	Positive Logic	Negative Logic
	Optional - P	Standard
Trim-Up	Trim Pin to +Sense	Trim Pin to -Sense
Trim-Down	Trim Pin to -Sense	Trim Pin to +Sense

Output Trim Logic

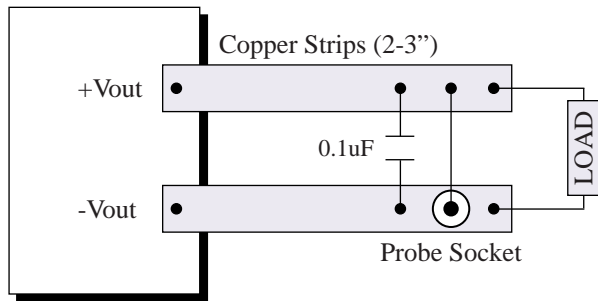

Output Ripple & Noise Measurement

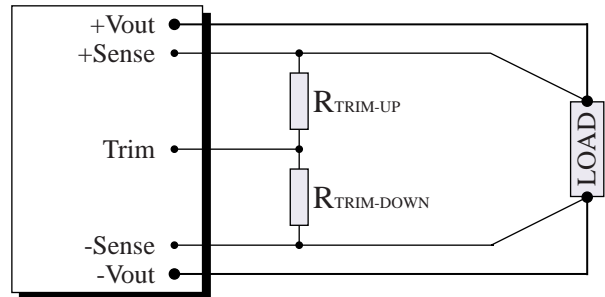

Positive Trim Logic

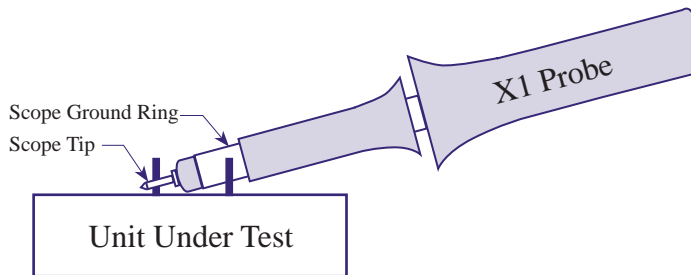

Simplified Ripple & Noise Measurement

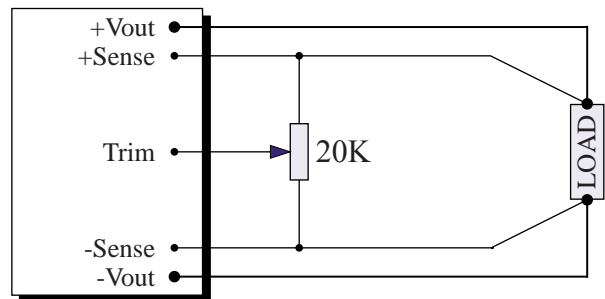

Trim Pot Connection

Output Loading

There is a minimum load required for most of converter output. Specially for those multiple output converters that use only one PWM (Pulse Width Modulator) controller. Load regulation is usually tested from minimum rated load to maximum rated load.

Output Overvoltage Protection

To Preventing damage to the user's circuitry in the event of broken feedback control loop, the main output is limited by an internal clamp typically @ 120% of rated output. An accurate overvoltage clamp can be implemented externally via the Enable pin.

Hiccup Mode Short Circuit Protection

Under output faulty condition (short circuit), the converter goes into hiccup short circuit protection mode and limits the output current both in peak value and duration time. Once the faulty condition removed, the converter automatically exits the hiccup mode and continues normal operation.

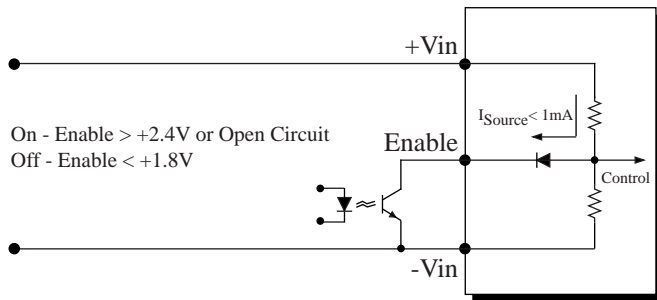

Thermal Impedance

The temperature rise of the converter is the product of power dissipation and thermal impedance, $T_{RISE} = P_{DISS} \times \theta$. The figure below illustrates the relationships of output power and temperature rise.

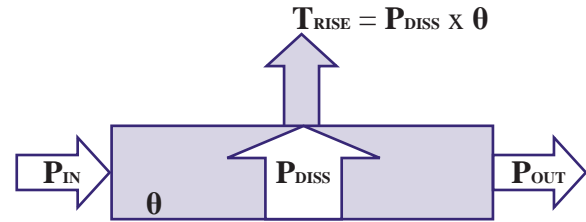

P_{OUT} , Output Power (Watt)

$\eta = P_{OUT}/P_{IN}$, Efficiency

$P_{IN} = P_{OUT} / \eta$, Input Power (Watt)

θ , Thermal Impedance ($^{\circ}C/Watt$)

$P_{DISS} = P_{IN} - P_{OUT}$, Power Dissipation

$T_{RISE} = P_{DISS} \times \theta$, Temperature Rise ($^{\circ}C$)

Temperature Rise

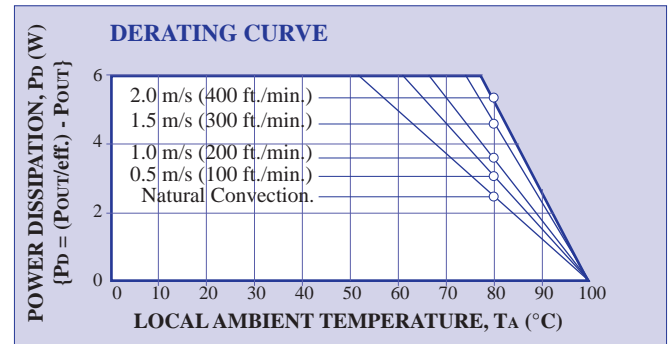

Typical Derating Curve

Capacitive Loading

Output capacitors draw charging current during the startup phase of DC-DC converters. This capacitive charging current become very significant specifically for high output voltage with high capacitive loading. The initial surge input current could exceed the current limit threshold and trigger the short circuit protection circuitry and send the converter running into the hiccup mode. Converters in hiccup mode show an abnormally low output voltage.

The circuit shown below can charge the 10000 μ F capacitor to 48V without triggering the converter protection circuitry.

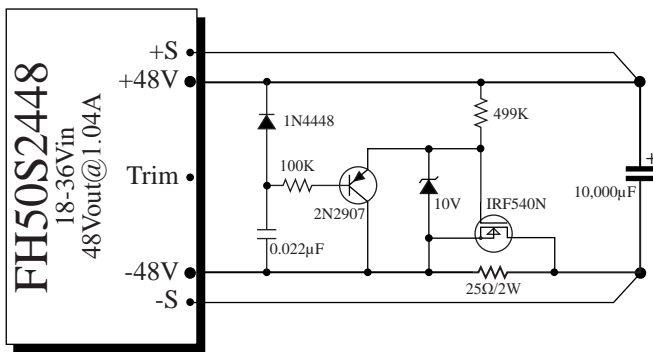

High Capacitive Load

Enable

This pin provides the remote On/Off control function. Two control logics are available: Positive & Negative. Positive logic turns the module ON during a logic high voltage on the enable pin, and OFF during a logic low. Negative logic turns the module OFF during a logic high and ON during a logic low. Positive logic is the standard factor configuration. Negative Enable Logic can be specified with suffix N. The Enable pin can be left floating if not used.

Sync-In

This pin can be connected either to external clock or directly to the Sync-In pin of another MKS, MKD or MKT module. If the Sync-In pin is connected to another module's Sync-In pin, the connection should be as direct as possible, and the Vin(-) pins of the modules must be shorted together. If an external clock signal is applied to the Sync-In pin, the signal must be a 300KHz (± 30 KHz) square wave with a ≥ 4 Vp-p amplitude. The Sync-In pin can be left floating if not used.

I-Share

Two or more modules can be operated in parallel for either redundant operation or additional power requirements. Connect I-Share pin together will force load sharing between the connected modules. To implement forced load sharing, the Sync-In pins of all units must be connected together also. The I-Share pin can be left floating if not used.

Sync-Out

This pin contains a clock signal referenced to the (-)Vout pin. The frequency of this signal will equal either the module's internal clock frequency or the frequency established by an external clock applied to the Sync-In pin. The Sync-Out pin can be left floating if not used.

PG (PWR GOOD)

The PWR GOOD pin indicates the operating state of the module. A TTL high indicates that the Vout is within $\pm 15\%$ of voltage set-point. A TTL low indicates that the Vout is out of regulation. The PG pin can be left floating if not used.

FET Drive

The *FET Drive* pin provides a DC voltage about 10V above the main output. It is suitable for driving an external FET in series with the (+)Vout. This allows for OR-ing the outputs in redundant operation or in turn-on sequencing operation. The *FET Drive* pin can be left floating if not used.

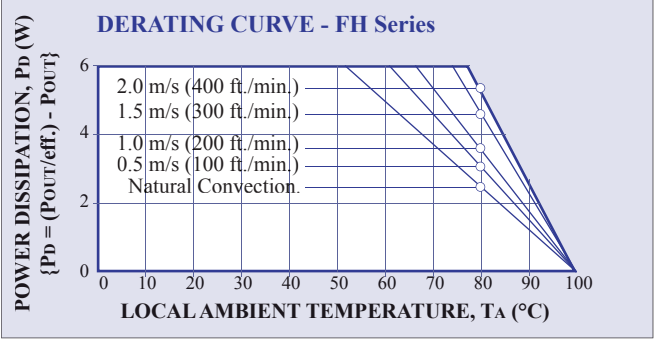
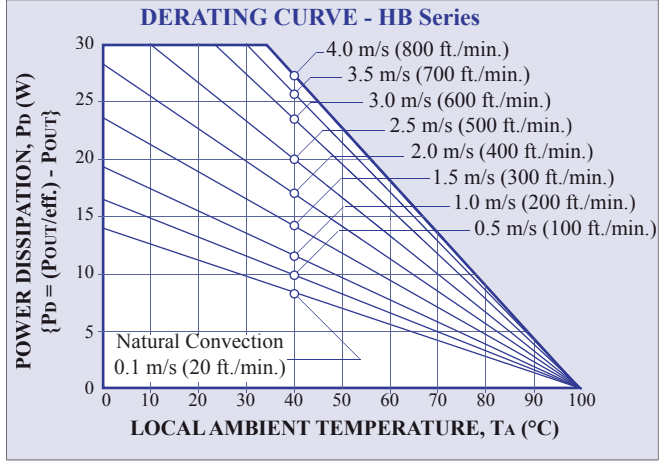
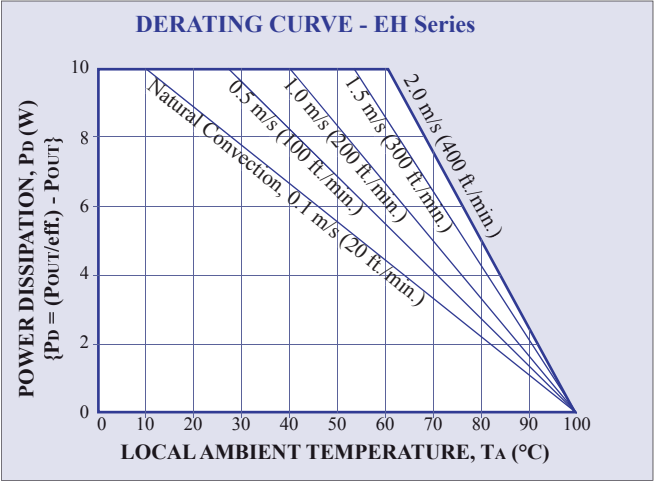
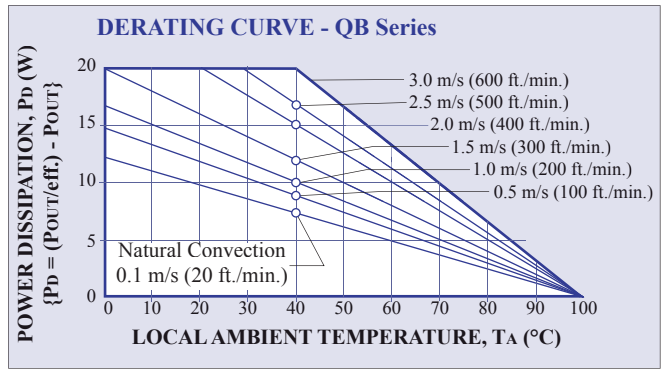
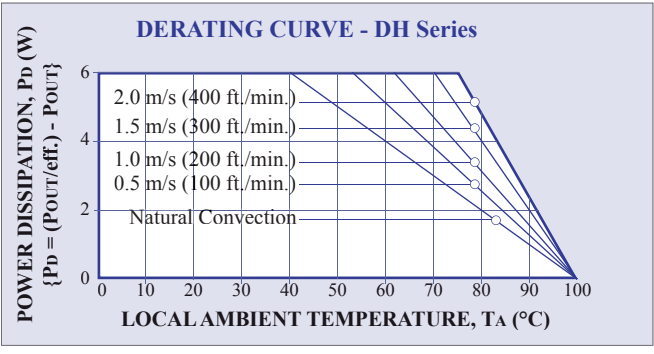

<p>Unless Otherwise Specified Dimension are in Inches (mm)</p> <p>Tolerances: Decimals .xx ± 0.020 .xxx ± 0.005</p>		<p>ACON, INC. 22 Bristol Drive, S. Easton, MA 02375 Tel : (508)230-8022 ; Fax (508) 230-2371 E-Mail : www.aconinc.com</p>	
Date	Model No.	DERATING CURVES	
	Rev:	1	Date: 11/4/02 SH 1 of 1



Exclusively distributed by Powerstax

Enable (On/Off Control) Pin

The Enable pin allows the power module to be switched on and off electronically. The Enable (On/Off) function is useful for conserving battery power, for pulsed power application or for power up sequencing.

The Enable pin is referenced to the -Vin. It is pulled up internally, so no external voltage source is required. An open collector (or open drain) switch is recommended for the control of the the Enable pin.

When using the Enable pin, make sure that the reference is really the -Vin pin, not ahead of EMI filtering, or remotely from the unit. Optically coupling the control signal and locating the opto coupler directly at the module will avoid any of these problem.

Two control logics are available: Positive & Negative. Positive logic turns the module ON during a logic high voltage on the enable pin, and OFF during a logic low. Negative logic turns the module OFF during a logic high and ON during a logic low. Positive logic is the standard factor configuration. Negative Enable Logic can be specified with suffix N.

If the Enable pin is not used, it can be left floating (positive logic), or connected to the -Vin pin (negative logic).

Enable :	Positive Logic	Negative Logic
ON - Control	Enable HIGH or FLOAT	Enable LOW
OFF - Control	Enable LOW	Enable HIGH or FLOAT

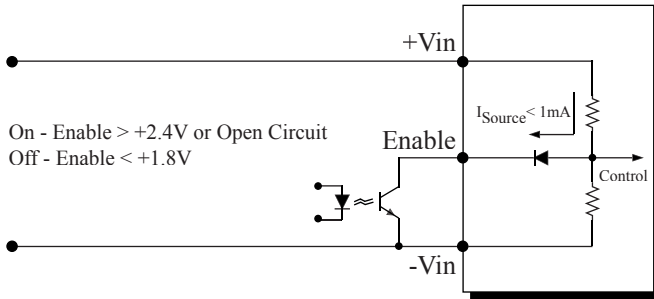

Sync-In

This pin can be connected either to external clock or directly to the Sync-In pin of another MKS, MKD or MKT module. If the Sync-In pin is connected to another module's Sync-In pin, the connection should be as direct as possible, and the Vin(-) pins of the modules must be shorted together. If an external clock signal is applied to the Sync-In pin, the signal must be a 300KHz (± 30 KHz) square wave with a ≥ 4 Vp-p amplitude. The Sync-In pin can be left floating if not used.

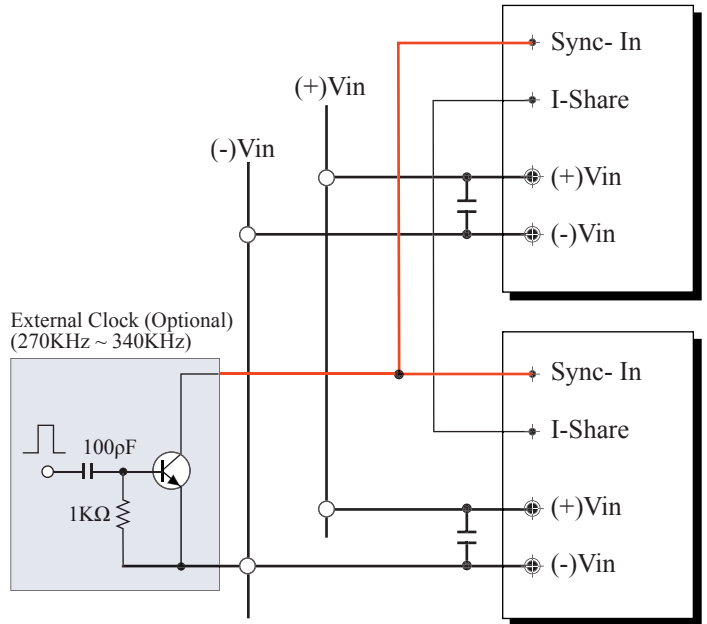

I-Share

Two or more modules can be operated in parallel for either redundant operation or additional power requirements. Connect I-Share pin together will force load sharing between the connected modules. To implement forced load sharing, the Sync-In pins of all units must be connected together also. The I-Share pin can be left floating if not used.

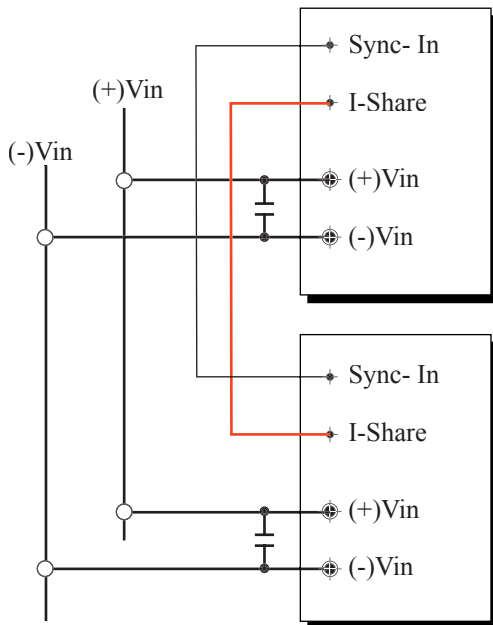

Sync-Out

This pin contains a clock signal referenced to the (-)Vout pin. The frequency of this signal will equal either the module's internal clock frequency or the frequency established by an external clock applied to the Sync-In pin. The Sync-Out pin can be left floating if not used.

ACON™ Pin Function Description

DC-DC CONVERTERS



Exclusively distributed by Powerstax

Trim Pin

Output voltage can be adjusted up or down with an external resistor. There are positive trim logic and negative trim logic available. For positive logic, the output voltage will increase when an external trimming resistor connected between the Trim and +Vout/+Sense pin. The output voltage will decrease when an external trimming resistor connected between Trim and -Vout/-Sense pin. A multi-turn 20KΩ trim pot can also be used to adjust the output voltage up or down.

Output Trim Logic:	Positive Logic	Negative Logic
	Optional - P	Standard
Trim-Up	Trim Pin to +Sense	Trim Pin to -Sense
Trim-Down	Trim Pin to -Sense	Trim Pin to +Sense

Output Trim Logic

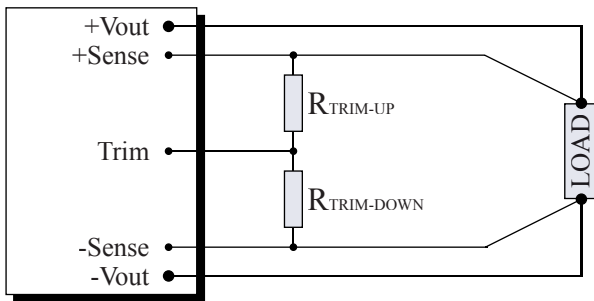

Positive Trim Logic

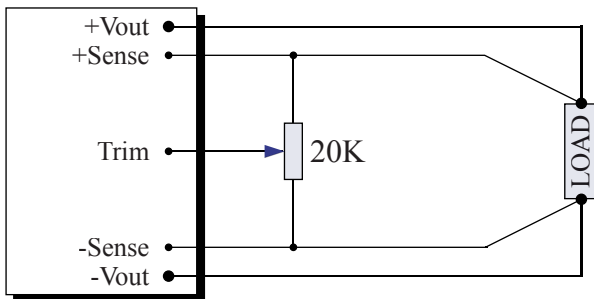

Trim Pot Connection

Sense Pin

Remote sensing allows the converter to sense the output voltage directly at the point of load and thus automatically compensates the load conductor distribution & contact losses (Fig. a). There is one sense lead for each output terminal, designated +Sense and -Sense. These leads carry very low current compared with the load leads. Internally a resistor is connected between sense terminal and power output terminal. If the remote sense is not used, the sense leads needs to be shorted to their respective output leads (Fig. b).

Care has to be taken when making output connections. If the output terminals should disconnect before the sense lines, the full load current will flow down the sense lines and damage the internal sensing resistors. Be sure to always power down the converter before making any output connections. The maximum compensation voltage for line drop is up to 0.5V

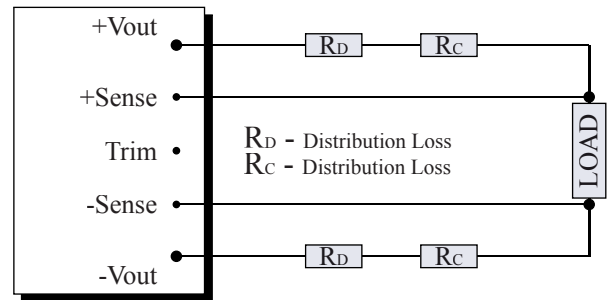

Fig. a Remote Sense Connection

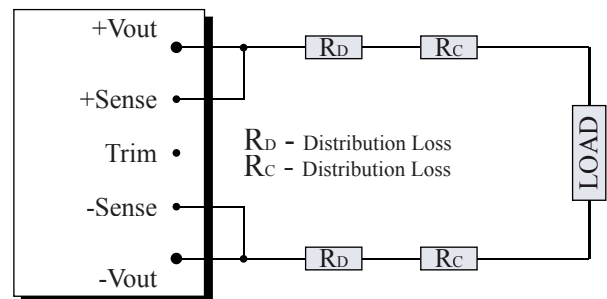

Fig. b Remote Sense is not Used.

FET Drive Pin

The *FET Drive* pin provides a DC voltage about 10V above the main output. It is suitable for driving an external FET in series with the (+)Vout. This allows for OR-ing the outputs in redundant operation or in turn-on sequencing operation. The *FET Drive* pin can be left floating if not used.

PG (Power Good) Pin

The PG pin is a “power good” signal. It will be asserted high by the converter to indicate that the output voltage is within $\pm 10\%$ of voltage set-point. Conversely, PG will be deasserted to a low stat when the output voltage falls below or rises above $\pm 10\%$ of voltage set-point

